

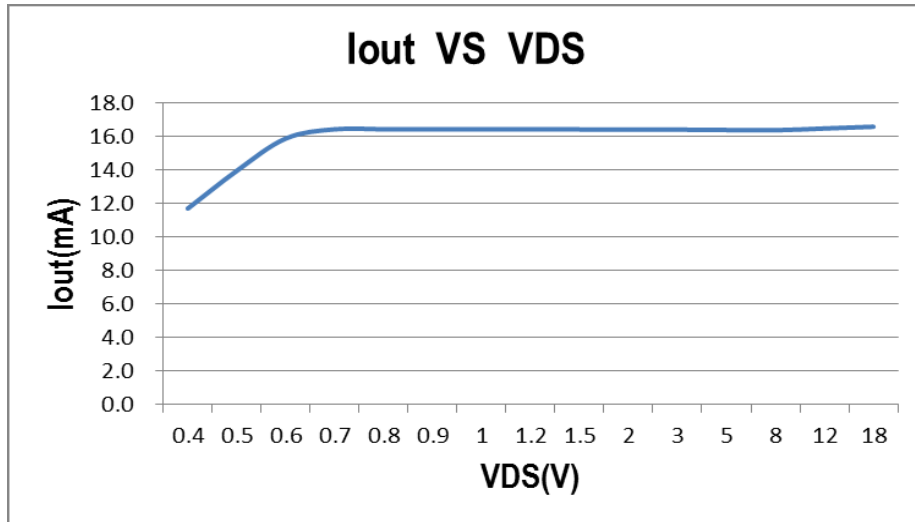

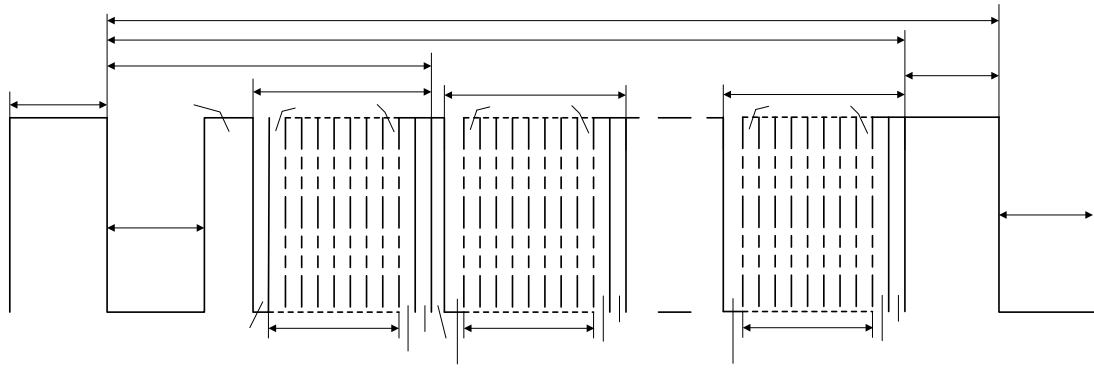

△						

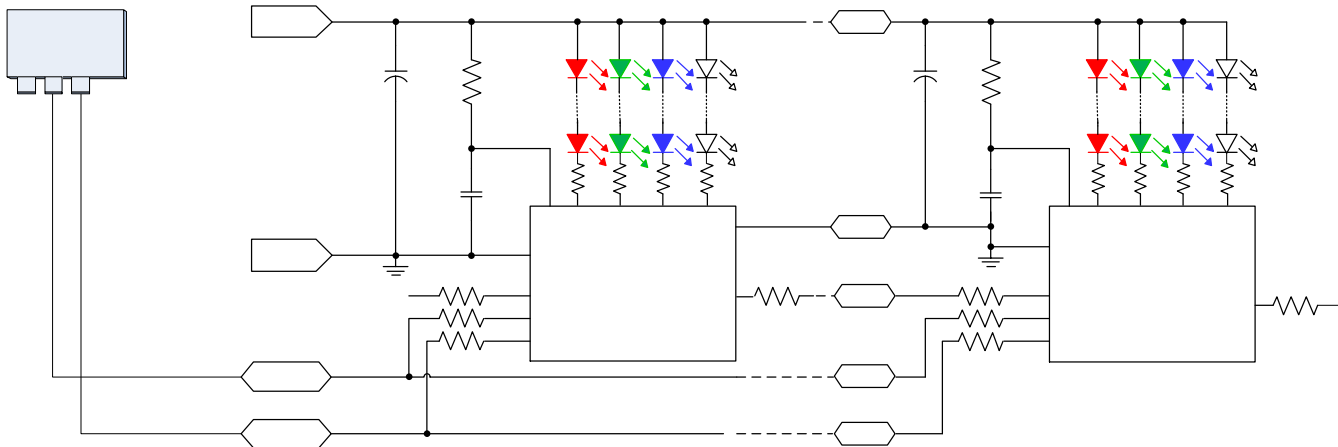

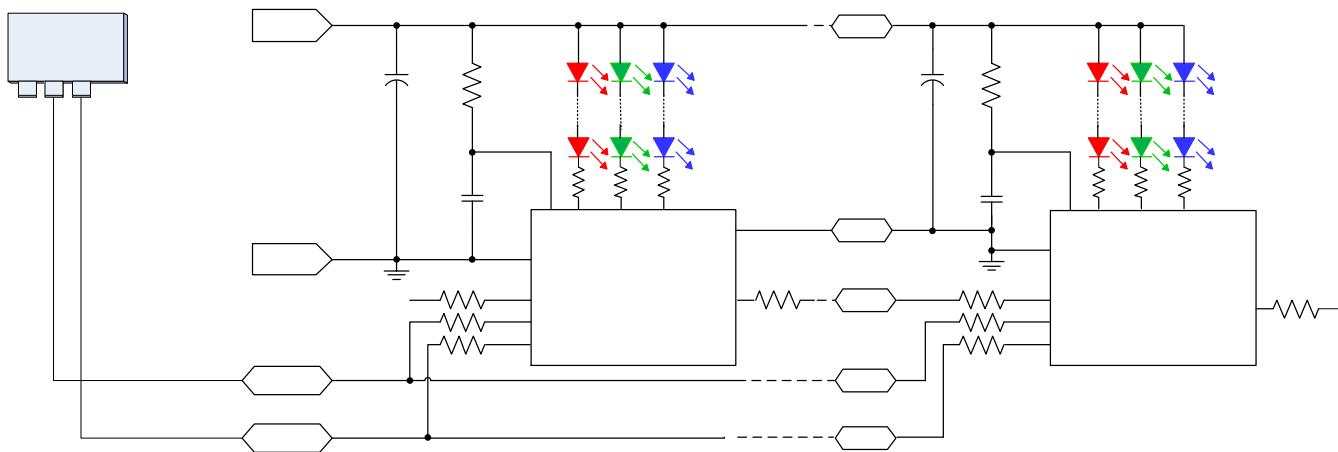

业务电话：400-033-6518

注：如需最新资料或技术支持，请与我们联系

$$\frac{V_{IN} - N * V_{LED} - V_{DS}}{I_{LED}}$$