

# SM16509

圳

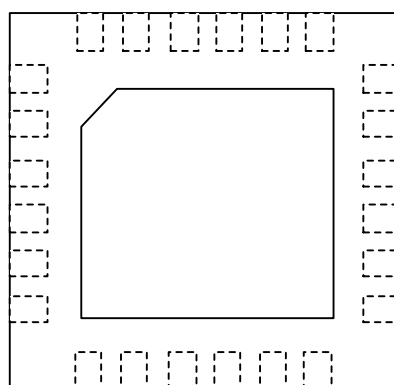

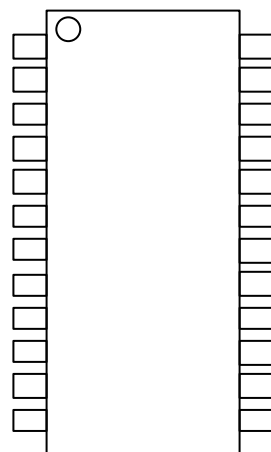
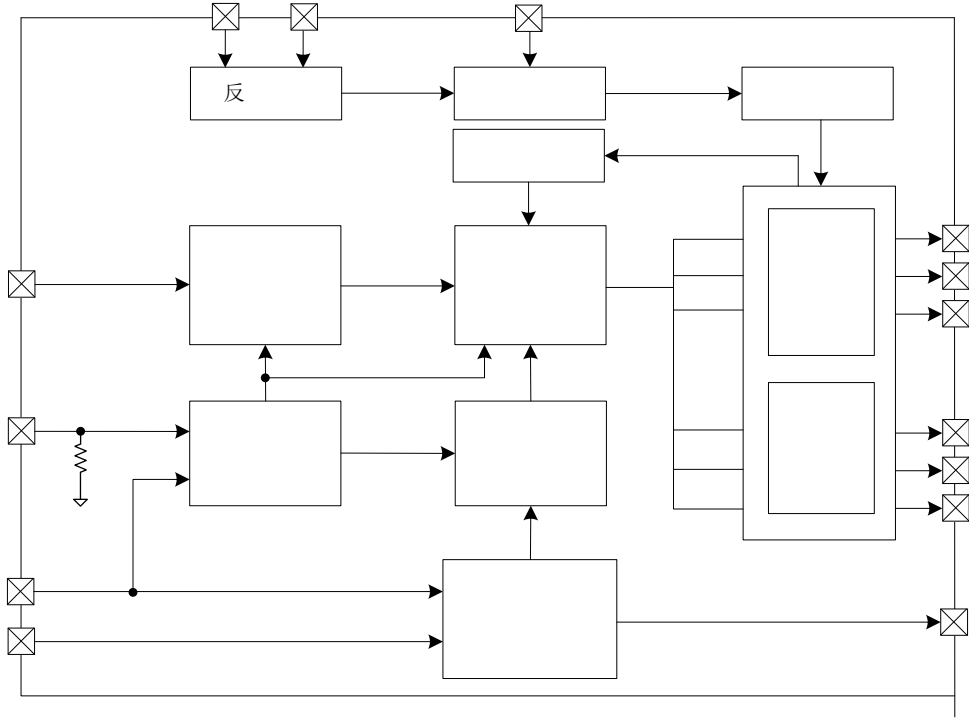

	下

反 1

			占

圳 反 企

制

反

	反	企				占
		$\Omega$				
		□				
		$\Omega$				
		$\Omega$				
	□					
	□					
						$\Omega$

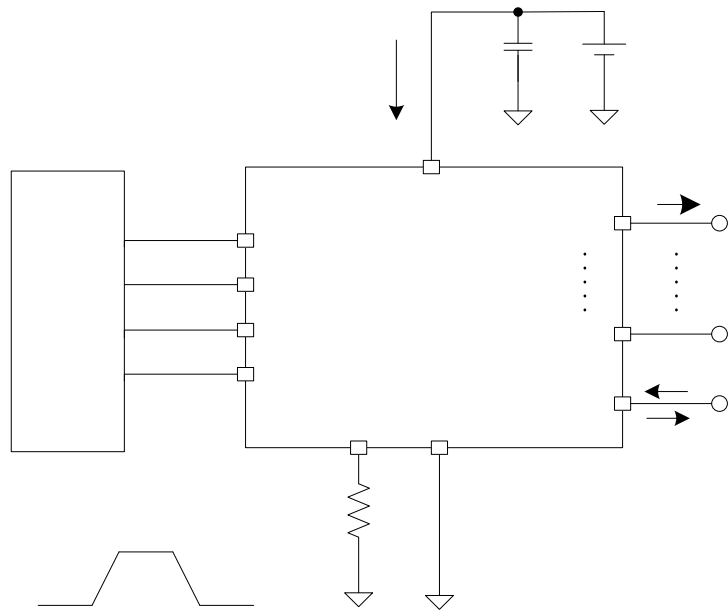

			企				占

			企				占
--	--	--	---	--	--	--	---

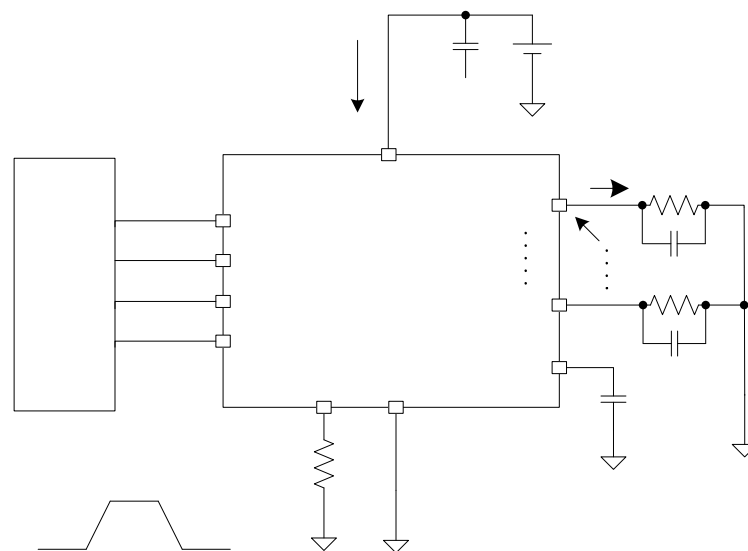
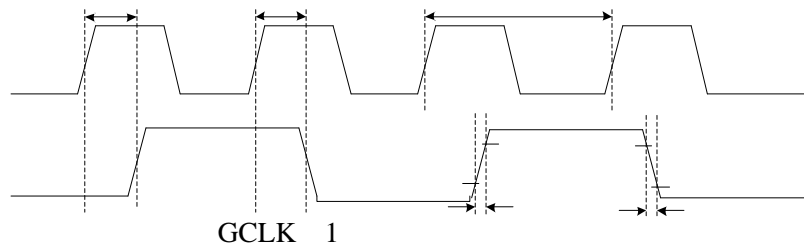
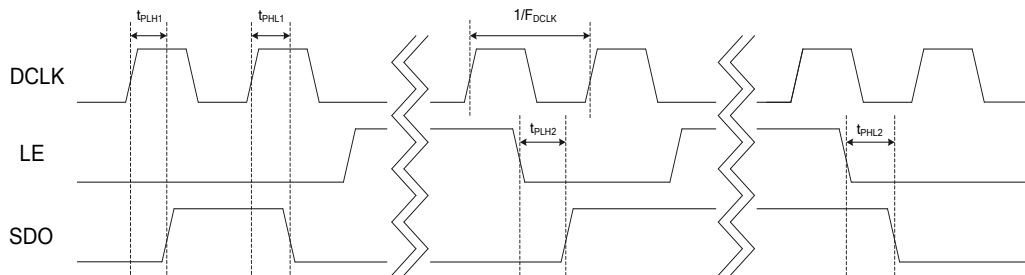
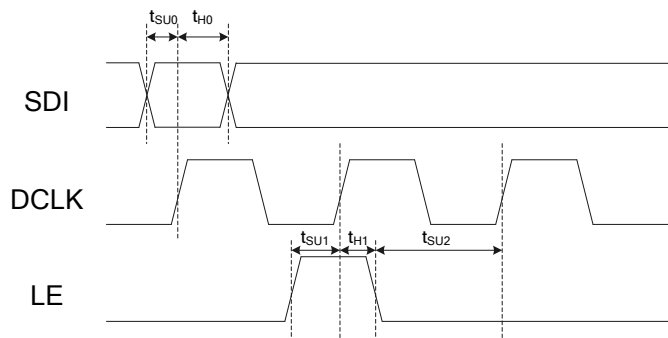

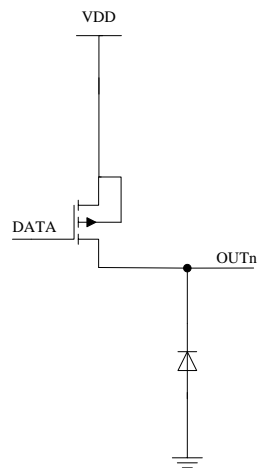
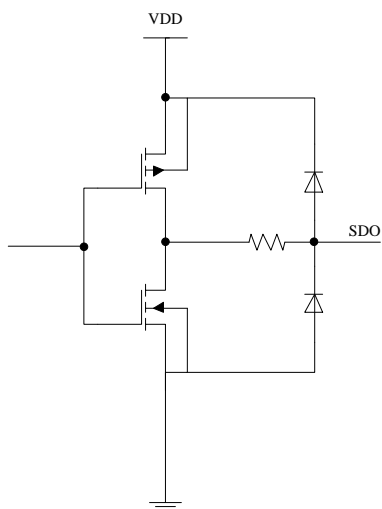
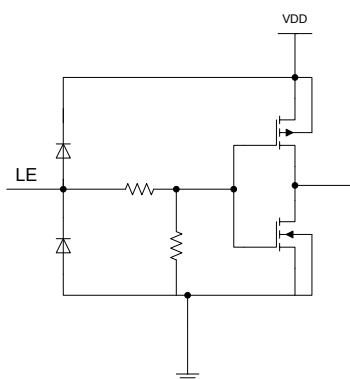
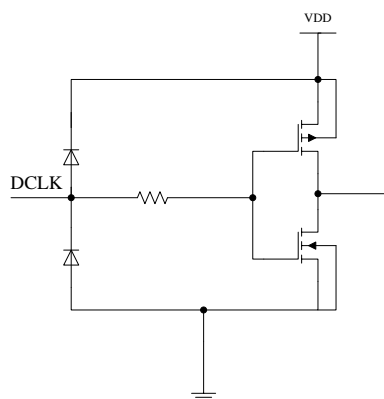



□

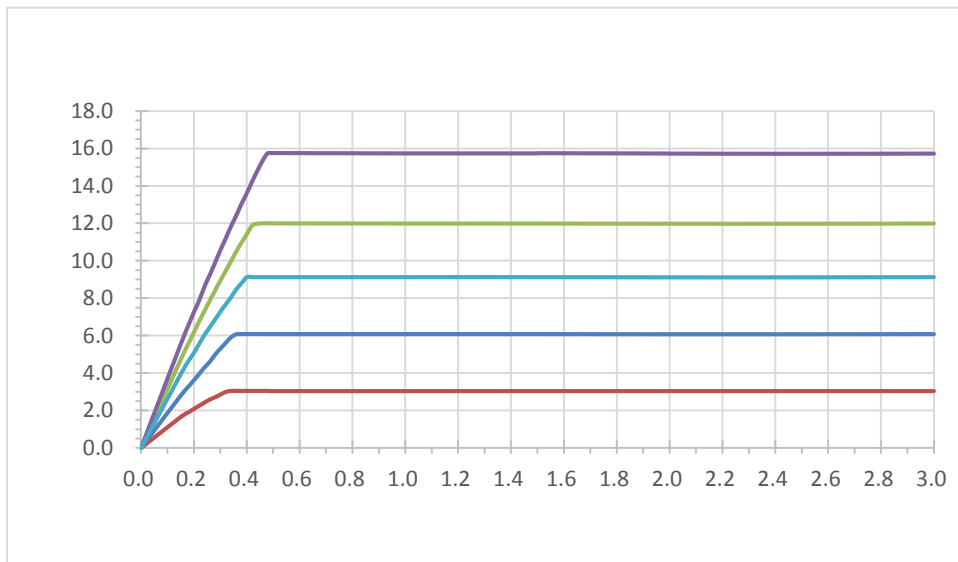
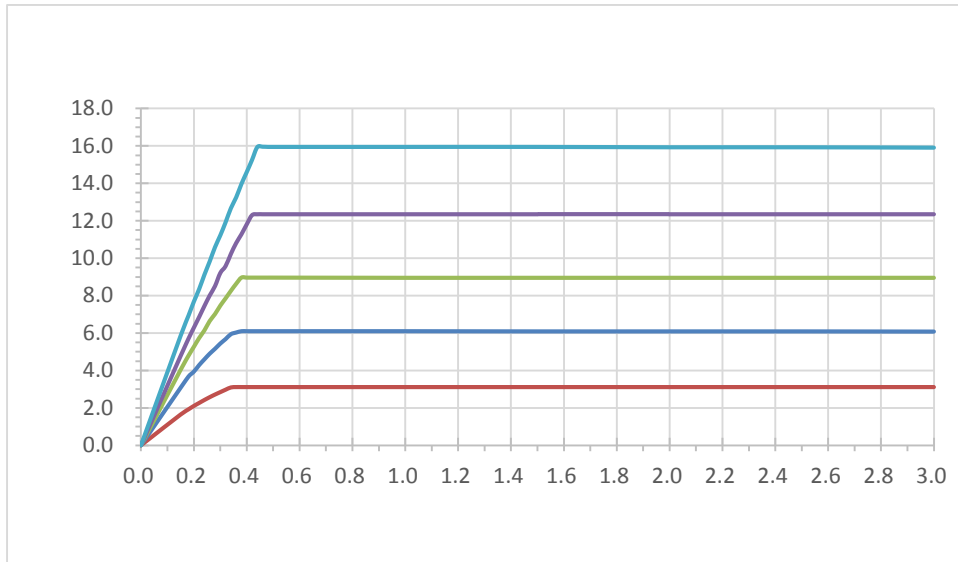

下

= ———

占

= ———

变

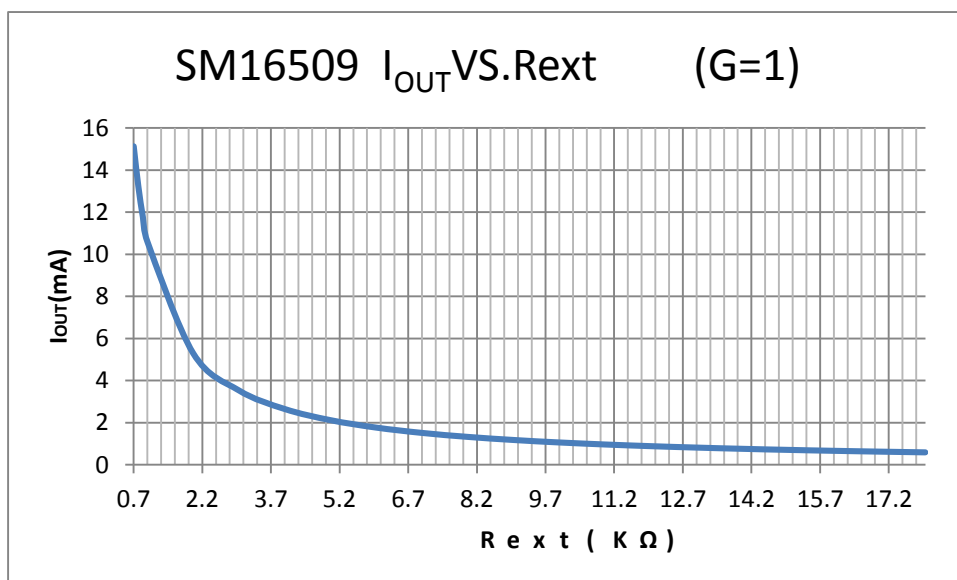

圳 企

$$= \overset{+}{\text{————}} + \text{—} + + + +$$

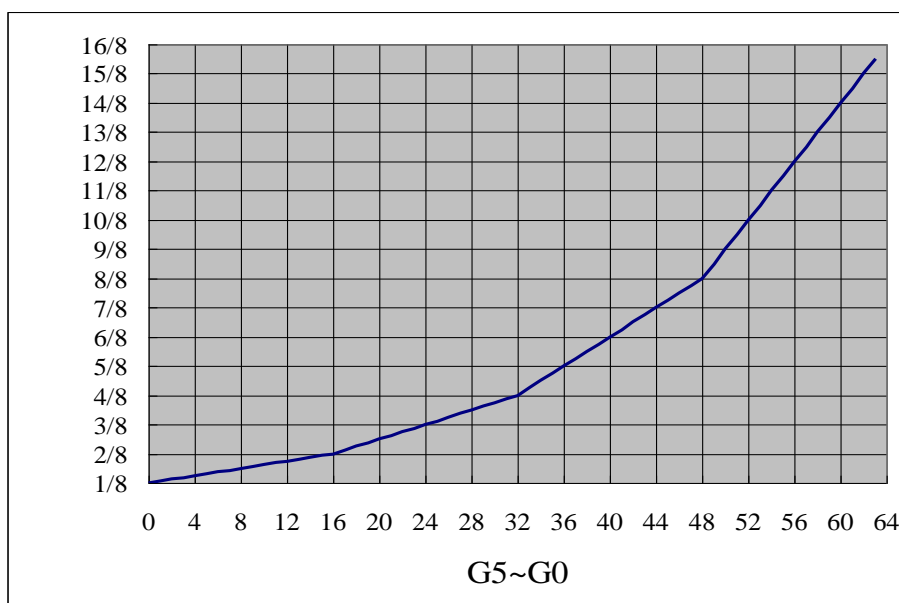



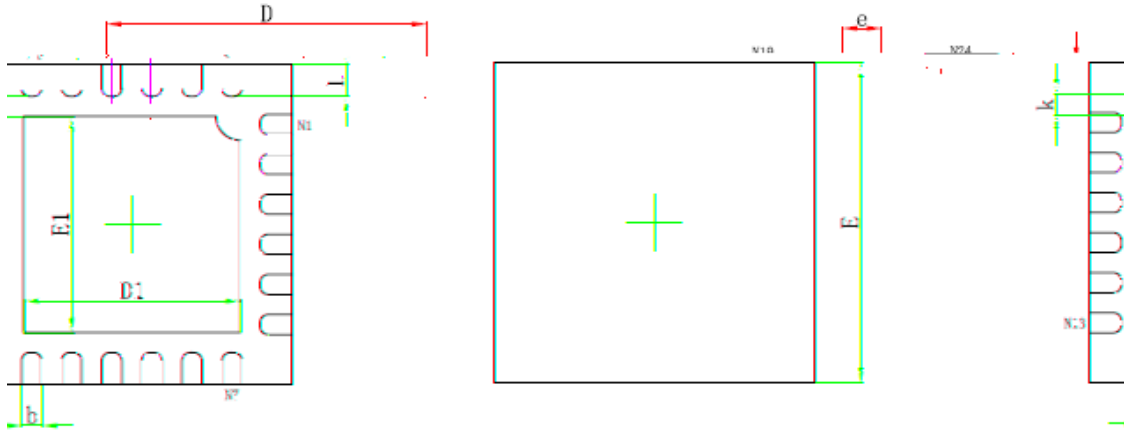

Bottom View

Top View

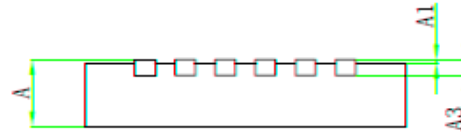

Side View

**(P<sub>D</sub>)**

$$P_{D(max)} = \frac{(T_j - T_a)}{R_{th(j-a)}}$$

$$I_{OUT} = \frac{T_j - T_a}{R_{th(j-a)}} \cdot \frac{V_D}{V_{DS} \cdot D \cdot t_{16}}$$

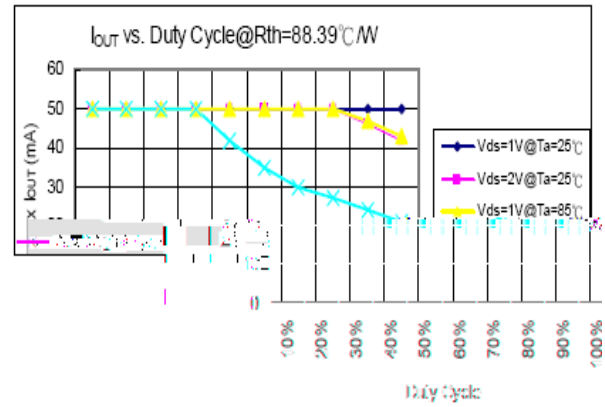
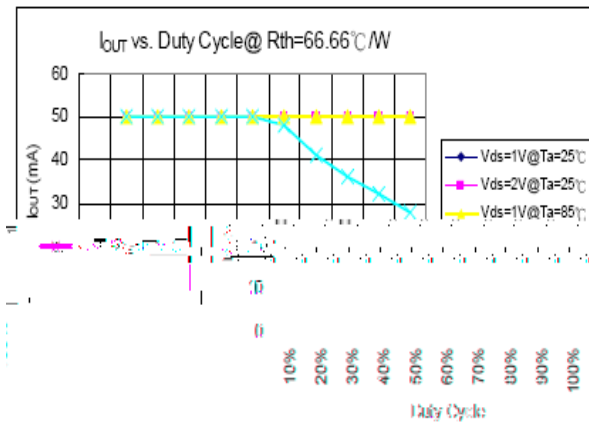

下

$$\frac{1}{R_{th(j-a)}} + \frac{1}{R_{fc}} = \frac{P_{D(act)}}{T_j - T_a}$$

$$R_{fc} = \frac{R_{th(j-a)} \cdot (T_j - T_a)}{P_{D(act)} \cdot R_{th(j-a)} - T_j + T_a}$$

单

	$\text{mm}^3 < 350$	$\text{mm}^3 \quad 350\sim 2000$	$\text{mm}^3 \geq \quad 2000$
--	---------------------	----------------------------------	-------------------------------

企 下 口 圳

企