

# SM16169SD

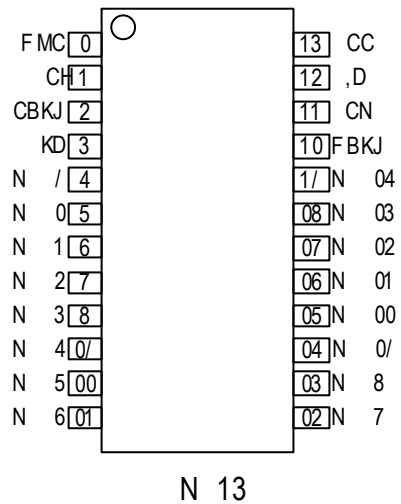

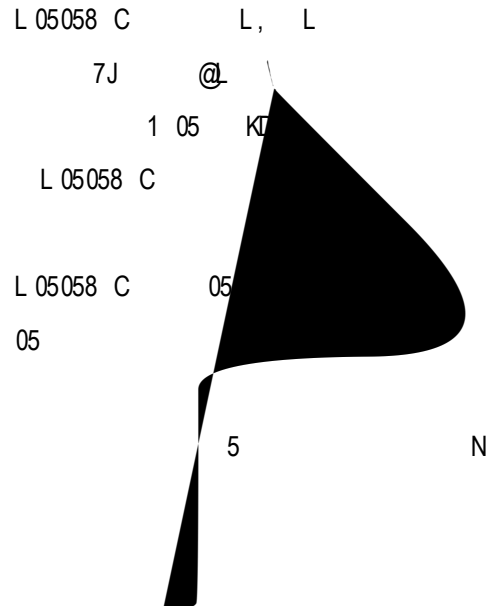
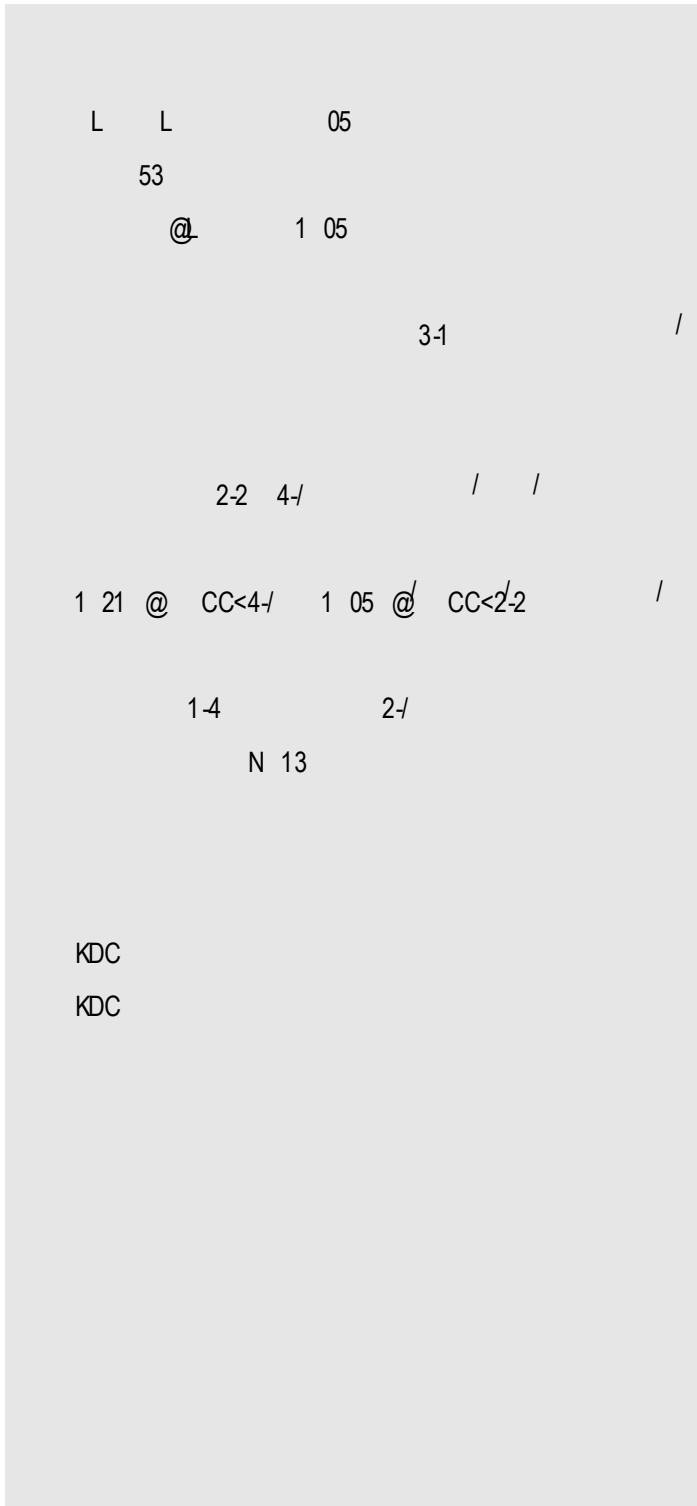
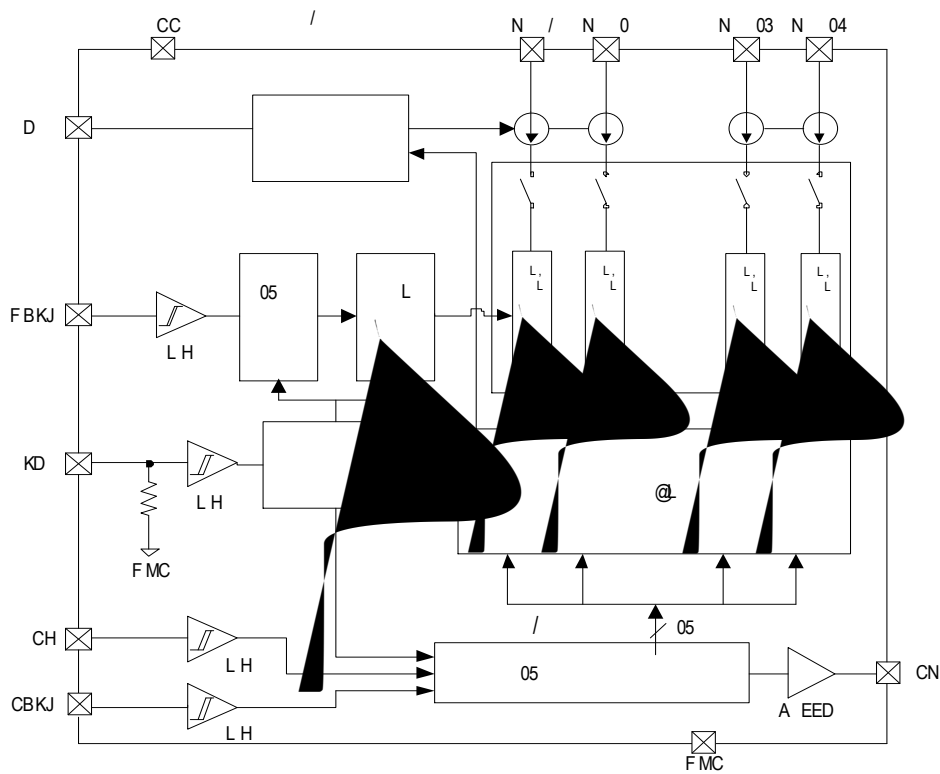

E - L 05058 C

0	FMC	
1	CH	
2	CBKJ	
3	KD	CBKJ
4 1/	N / N 04	
10	FBKJ	
11	CN	CH
12	,D	
13	CC	

L 05058 C	N 13	4/111 .	3/111 .	02
-----------	------	---------	---------	----

业务电话：400-033-6518

注：如需最新资料或技术支持，请与我们联系

CBKJ FBKJ CH

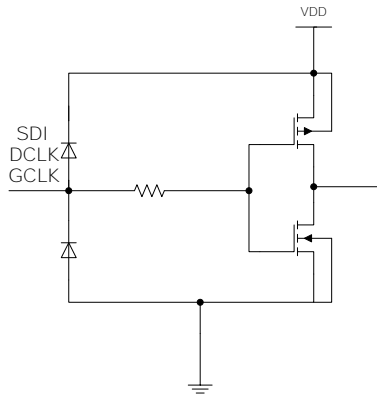

KD

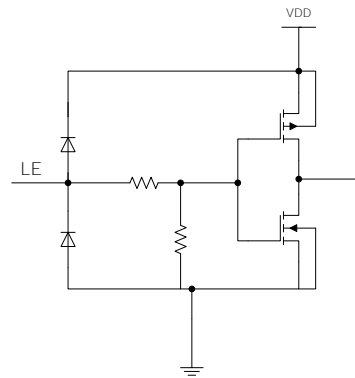

CN

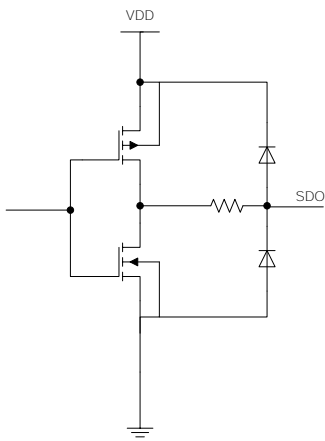

N / N 04

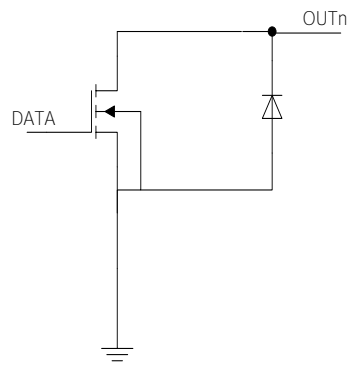

1

@14 B

CC		/ 6/	
HM		,/3 cc*/3 /	
H	N	21	@
EFBJ		22	LG
ECBJ		2/	
		,3/ *04/	
		,44 *04/	
D C	GAL	=3	J

0

CC<3-1 @14 B' /

H <sub>CC0</sub>		-	,	1-4	,	@
H <sub>CC1</sub>		- < 0-7JΩ H NEE	,	2-7	,	@
H <sub>N</sub>	N	N	1	,	21	@
H <sub>G</sub>	CN	CC<3-1 /	,	,11	,	@
H <sub>NK</sub>			,	11	,	@
H <sub>G</sub>	CH	CC<3-1 /	/-6) CC	,	,	
H <sub>K</sub>			,	,	/-2) CC	
NK	CN	H <sub>K</sub> <*0 @	,			

CC<2-2 <14 / /

H <sub>CC0</sub>		-	,	1-2	,	@
H <sub>CC1</sub>		- < 0-7JΩ H <sub>N</sub> NEE	,	2-5	,	@
H <sub>N</sub>	N	CC<2-2 N / /	1	,	05	@
H <sub>G</sub>	CN	CC<2-2 /	,	,0/-	,	@
H <sub>NK</sub>			,	00-4	,	@
H <sub>G</sub>	CH	CC<2-2 /	/-6) CC	,	,	
H <sub>K</sub>			,	,	/-2) CC	
NK	CN	H <sub>K</sub> <* 0 @	,	,	/-2	
NG		H <sub>G</sub> < 0 @	2/-	,	,	
H <sub>0</sub>	0	c < 0	D < 81/Ω F < 0	,	00-3	@
H <sub>0</sub>			H <sub>0</sub> < 00-3 @	,	1-4	,
			c < 0/-		2/-	,
H <sub>1</sub>	1	c < 0/-	D < 2JΩ F < 0	,	2-4	@
H <sub>1</sub>			H <sub>1</sub> < 2-4 @	,	1-4	,
			c < 0/-	,	2/-	,
. c	. c	c < 0/- 2/- H' < 00-3 /@ /	,	0		.
. CC	. CC	CC<2-2 2-7 H' < 00-3 /@ /	,	0		.
H <sub>M</sub> (	,	KD	,	05/	,	JΩ

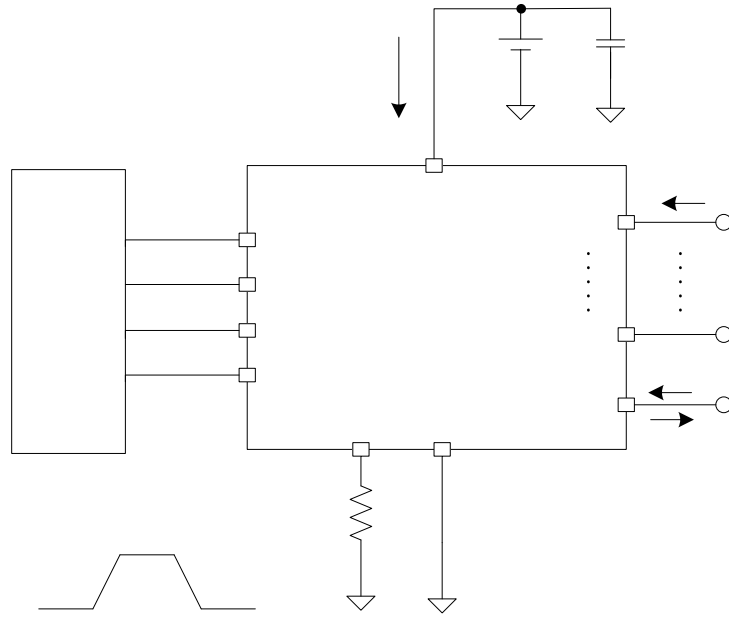

CC<3-1 @<14 / /

KG0		FBKJ N	CC<3-1 16< CC 1K<F MC - </-81J K<2// B0<0// E B1<0/ E BK<0/ E B CN<0/	,	5/	,	
KG1		CBKJ CN		,	16	,	
GK0		FBKJ N		,	64	,	
GK1		CBKJ CN		,	17	,	
N				,	54	,	
NE				,	75	,	
ECBKJ				,	,	2/	LG
EFBKJ				,	,	22	LG

CC< 2-2 @<14 / /

KG/		FBKJ N	CC<2-2 16< CC 1K<F MC - </-81J K<2// B0<0// E B1<0/ E BK<0/ E B CN<0/ E	,	54	,	
KG0		CBKJ CN		,	20	,	
GK/		FBKJ N		,	71	,	
GK0		CBKJ CN		,	20	,	
N							





0(

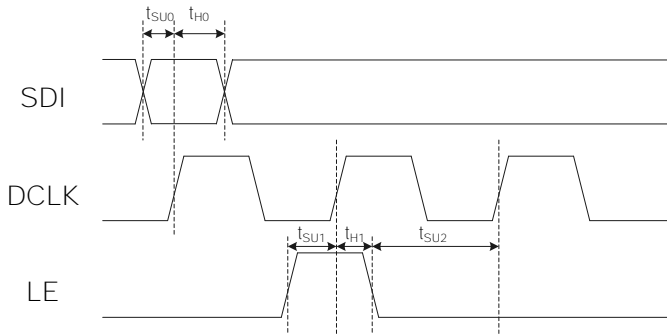

1(

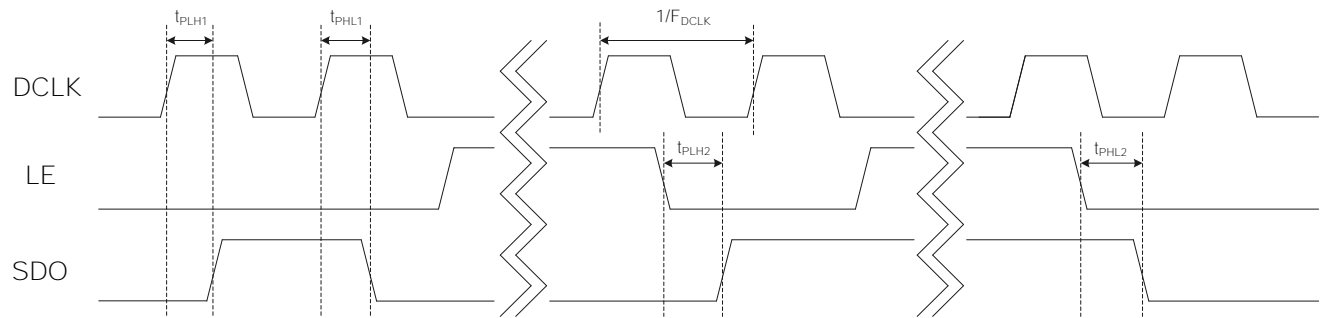

2(

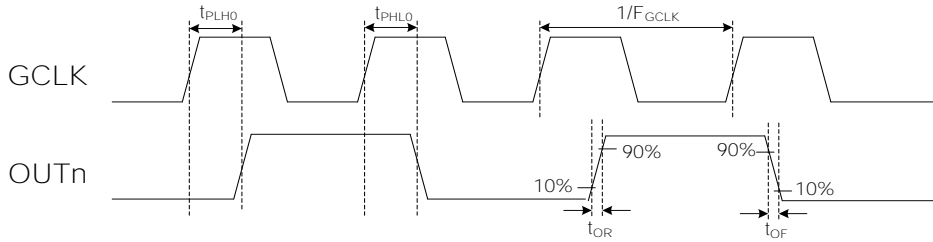

L 05058 C

L 05058 C

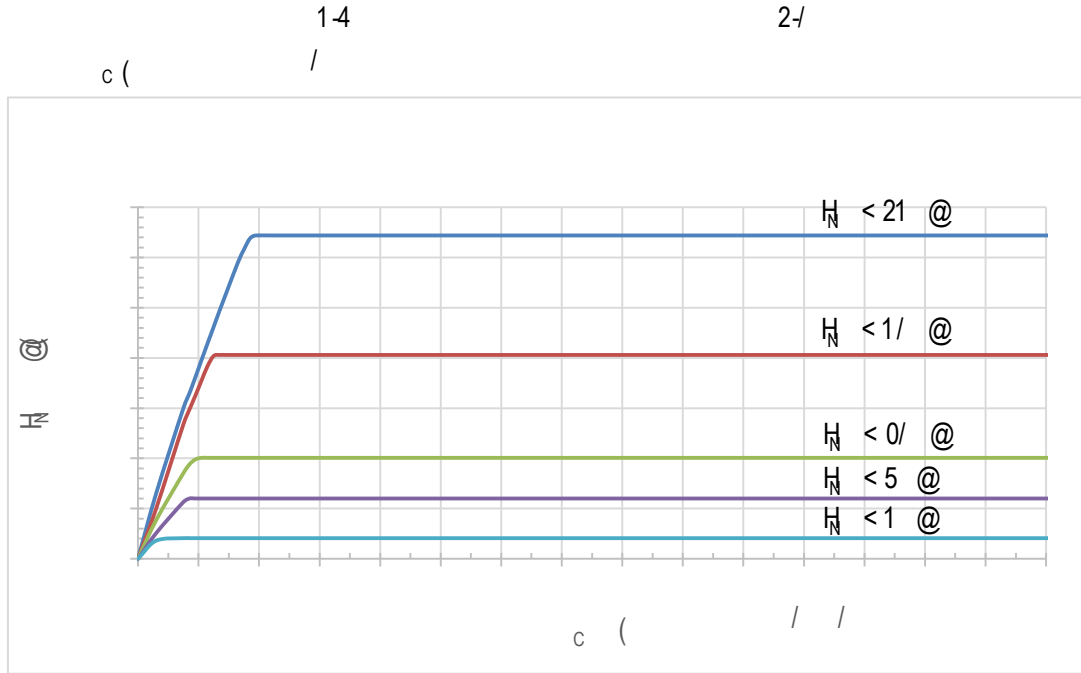

E - L 05058 C H

H

$$H_N = \frac{0/346}{D} ) F @$$

D

D

@ F

F < 0

Q

2/ / /

H < 0/346.2/ / / < 2-4 @

1(

0/ @

- < 0/346.0/ < 0/34-6

-

H

/

E - L 05058 C H - D /

L 05058 C

5 // // // // //

5 00 0000

53

E D C B A @ 8 7 6 5 4 3 2 1 0 /

(P)

---

(V<sub>LED</sub>)

$C < KDC, E$   
 $KDC$

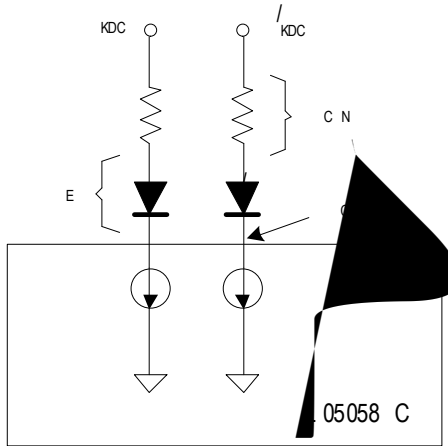

$c ($   
 $c ($   
 $c ($

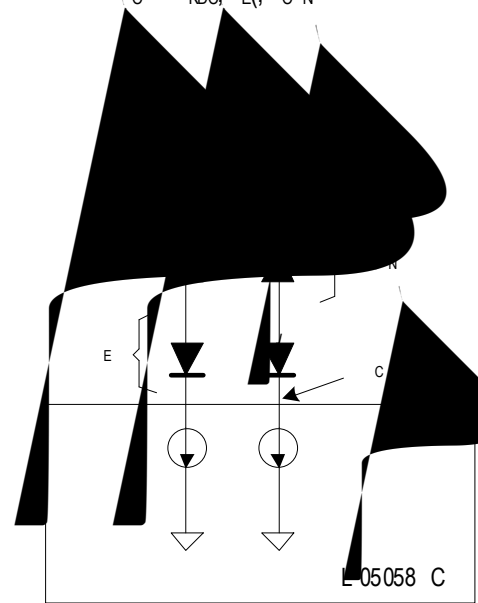

G

I, C,1/1/

0-5	$\text{mm}^3 < 350$ 15/*/	$\text{mm}^3 \quad 350\sim 2000$	$\text{mm}^3 \geq 2000$
-----	------------------------------	----------------------------------	-------------------------

N 13

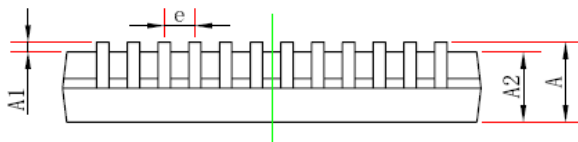
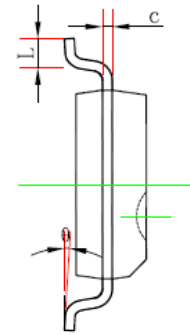
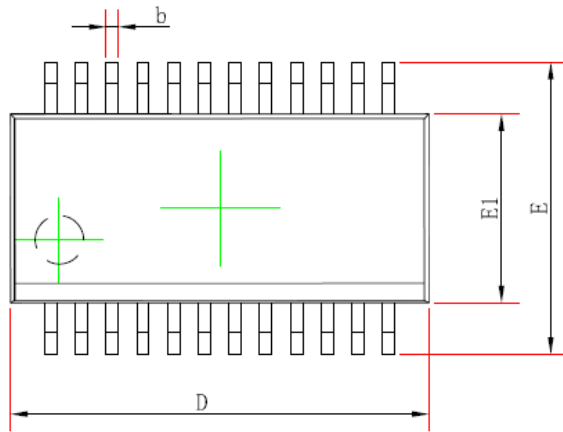

	L (	L (
@	,	0-84
@	/-4	/-24
@	0-4	,
	/-0	/-3
-	/-4	/-143
C	7-1	8-1
D0	2-5	3-1
D	4-5	5-4
-	/ -524	
K	/-2	0-4
	/	0/